



▶ **How to protect your critical infrastructure assets against drones**

▶ FIELDctrl – ultra-precise 3D MIMO radars

▶ SKYctrl modular anti-drone system

▶ Robert Fintak, MBA Terra Hexen

March 2021

▶ TERRA HEXEN is the official sales representative of APS





Maciej Klemm, PhD
CEO and cofounder

Radosław Piesiewicz, PhD
COO and cofounder



"Defender" award,
for outstanding and innovative
defence solution.
Granted by the Secretary of State
in Ministry of National Defence



President of the Board Award
at the XXV International
Defence Industry Exhibition
(MSPO) in Kielce, Poland



"Innovations
for the Armed Forces
of Republic of Poland"
award.



Medal
from The Armed Forces
Operational
Command of Poland



Innovative high-tech company designing and manufacturing systems and electronic products for **security** and **defence** markets.



Offices in **the UK** and **USA**. R&D: **Poland**.



Clients: Poland, United Kingdom, Norway, Czech Republic, Finland, Estonia, Saudi Arabia, Singapore, India, Malaysia, South Korea.



Focus on critical infrastructure, law enforcement, and military.



Granted not only with the trust of our clients but with **prestigious awards** and prizes too.



Conducting world class R&D activities – proprietary 3D MIMO radar technology and jammers



TERRA HEXEN is the official sales representative of APS



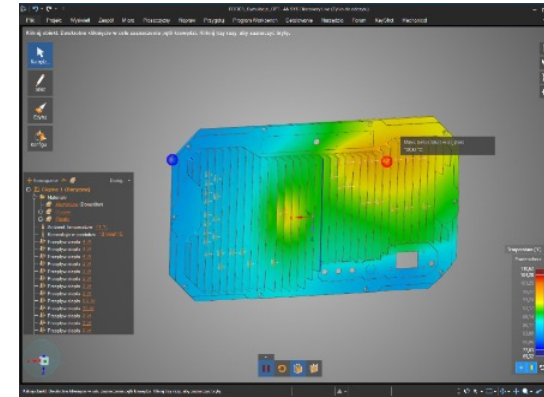
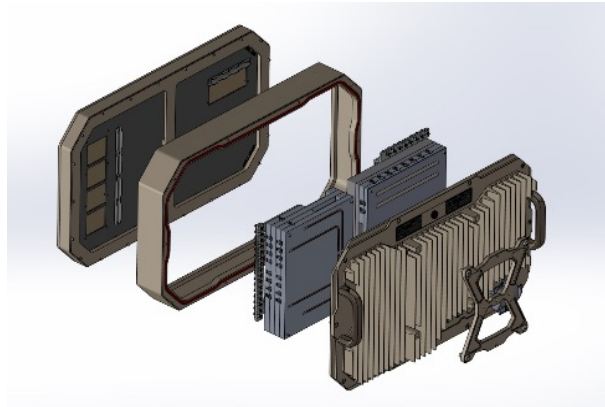
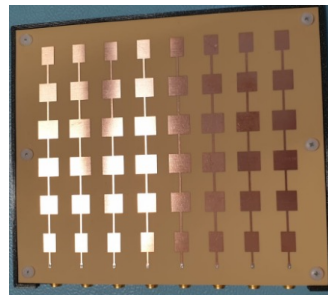
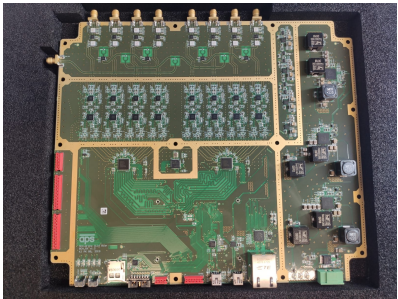
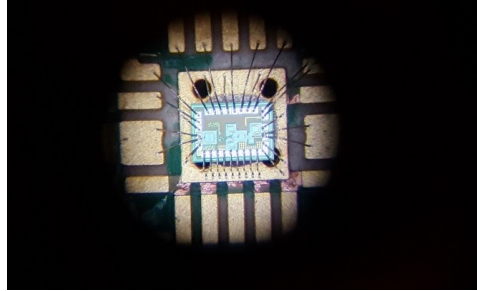

- ▶ **World-class R&D** activities in the areas of radar sensing, antennas, integrated circuits, electromagnetics.
- ▶ Know-how based on extensive R&D work across numerous projects and contracts for high profile organisations in Europe – European Space Agency, EDA, NCBiR.
- ▶ Strong focus on jammers and radar sensors, covering **HW, SW, DSP, antennas and mechanics**.

▶ **WORLD CLASS R&D, TRUSTED BY ESA AND EDA**



- ▶ Based on in-house R&D we develop and commercialise 2 product lines of advanced electronic products: **SKYctrl modular anti-drone system** and FIELDctrl 3D MIMO radars family.
- ▶ We have already delivered them to clients representing military and defence industry, uniformed services, **critical infrastructure**, prisons, ports and airports on **4 continents**.



▶ SKYctrl stationary



▶ SKYctrl mobile



▶ SKYctrl defence

▶ SKYctrl MODULAR ANTI-DRONE SYSTEM



- ▶ Based on in-house R&D we develop and commercialise 2 product lines of advanced electronic products: SKYctrl modular anti-drone system and **FIELDctrl 3D MIMO radars family**.
- ▶ We have already delivered them to clients representing **military** and **defence industry**, uniformed services, critical infrastructure, prisons, ports and airports on **4 continents**.
- ▶ **API and Prediction Software Tool** is delivered with each radar for easy integration and to facilitate site deployment

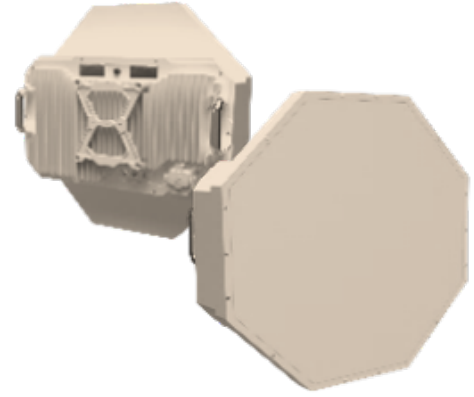
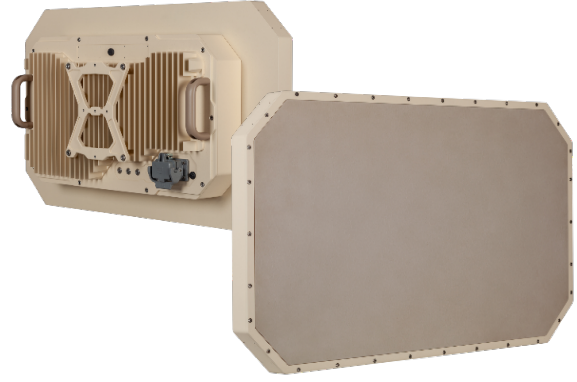
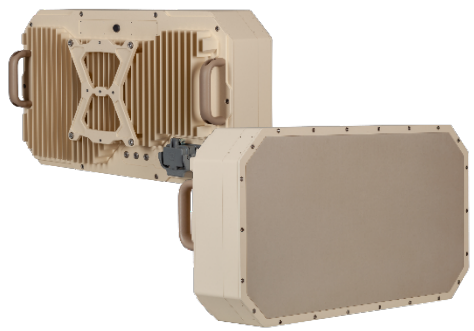

▶ **FIELDctrl**
Access

▶ **FIELDctrl**
Advance

▶ **FIELDctrl**
Range

▶ **FIELDctrl**
Runway

▶ **FIELDctrl ULTRA-PRECISE 3D MIMO RADARS FAMILY**



INNOVATIVE AND EFFECTIVE

obsolete



Poor detection and refresh rate.



Moving parts may eventually break.



Sweeps detection cones from one corner to the other to observe the entire sight.

It worsens detection quality.

▶ AESA



MIMO detects within entire sight **at once**. It radically improves detection quality and refresh rate.

3D provides full information about position of the object including altitude.

No moving parts = better **operational availability**.

3D MIMO

▶ ROTATING RADARS

▶ WHY 3D MIMO RADAR IS MORE VIABLE SOLUTION FOR DRONES DETECTION?



▶ **MIMO** is seeing like a fly.
Every part of sight at once.

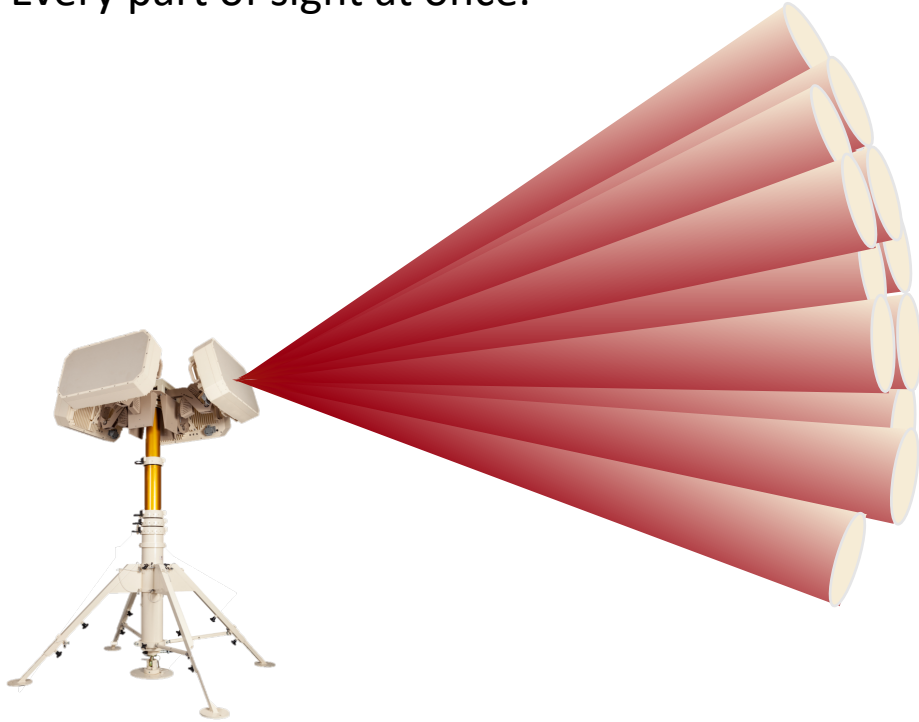

▶ **MIMO** stands for amazing refresh rate, which dramatically improves detection and tracking, including drone swarms.

Source: Internal materials.

▶ **MIMO vs AESA KEY DIFFERENCE**

▶ **AESA** is seeing like a human.
You have to sweep retina from one corner to the other to observe the entire picture.

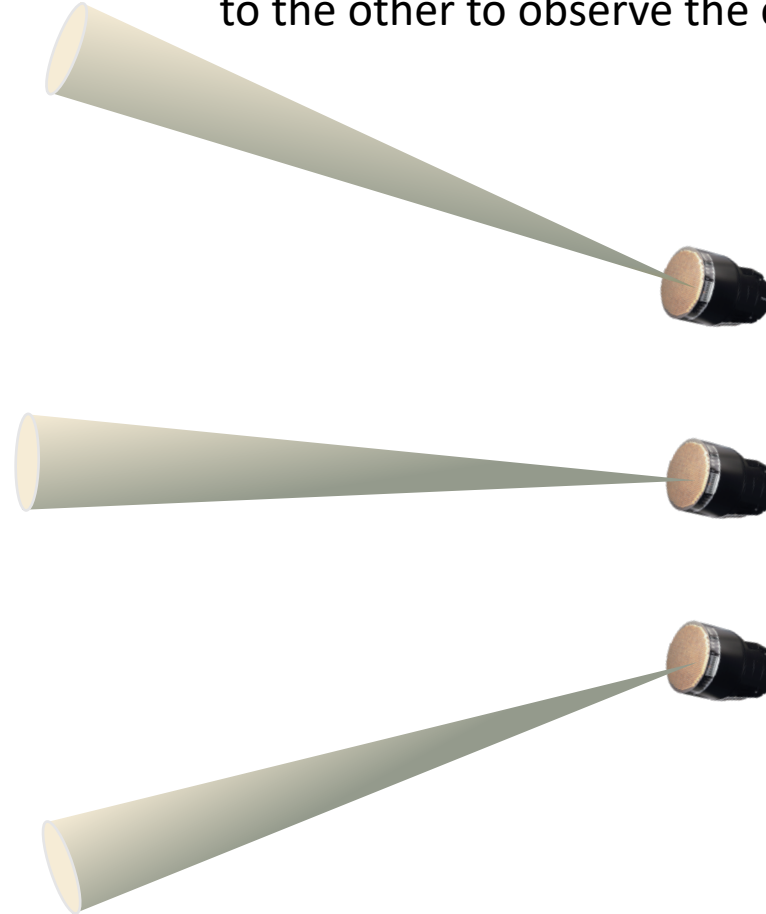

▶ **FIELDctrl
Access**



▶ **FIELDctrl
Advance**

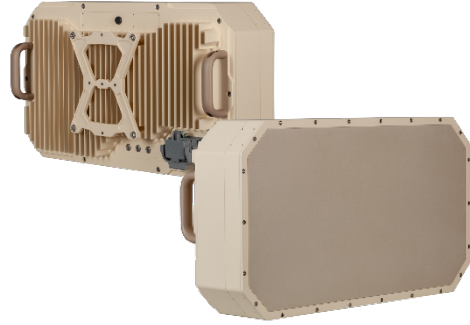

▶ **FIELDctrl
Range**



▶ **FIELDctrl
Runway**

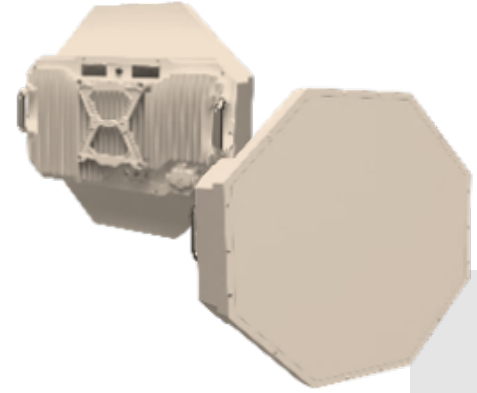

Instrumented range	7 km	30 km	50 km	50 km
Azimuth/elevation	360°/45°	360°/60°	360°/20° - 30°	20°/10°
Refresh rate	5 Hz	4 Hz	4 Hz	20 Hz

Source: Internal materials.

▶ **FIELDctrl 3D MIMO RADARS FAMILY**

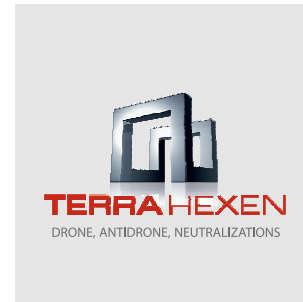

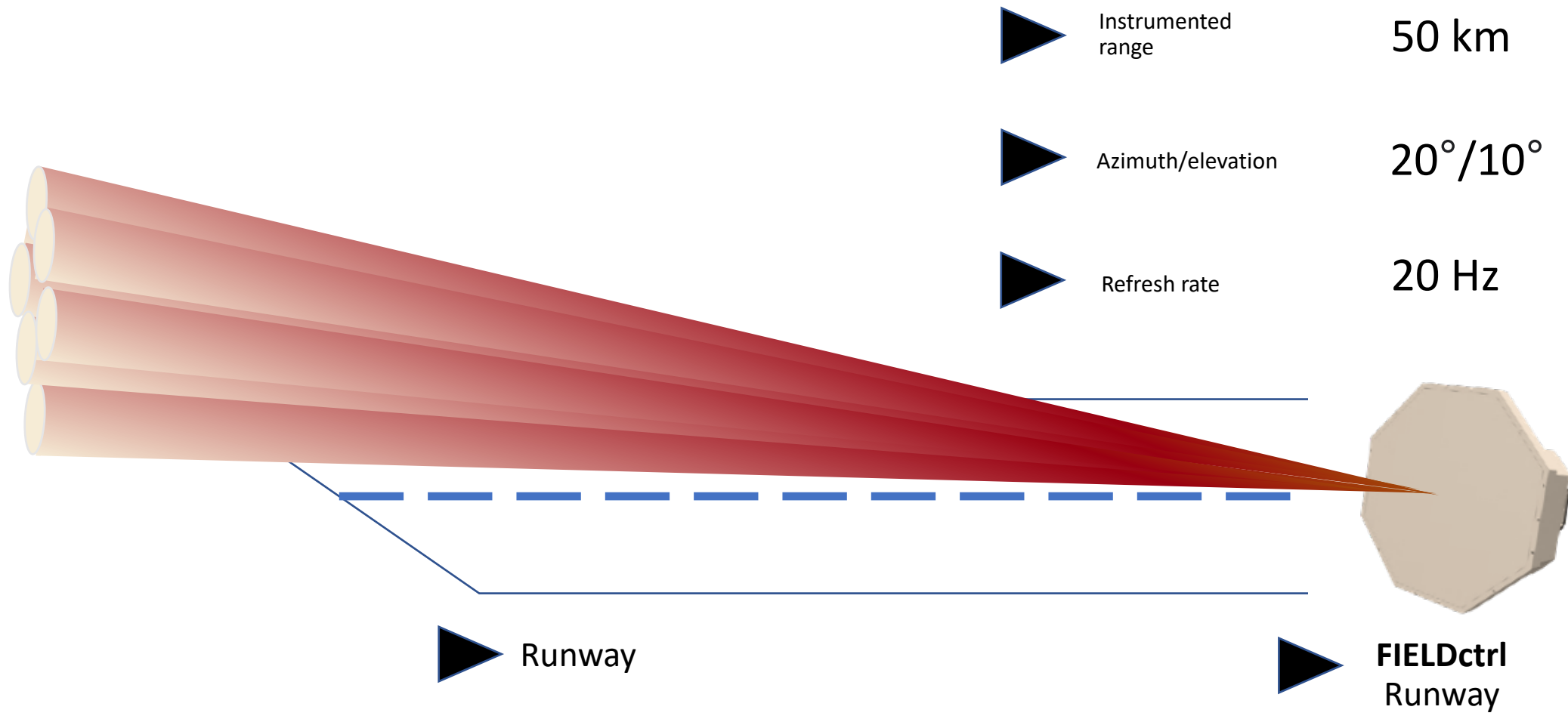

▶ HOW FIELDctrl RUNWAY WORKS





- ▶ APS proprietary jammer covers **various bands**: ISM, VHF, UHF, GSM, UMTS, LTE, GNSS, WiFi, UKF.
- ▶ APS jammer works with sectorial antennas in **1:5 ratio**. It means that jammer range equals to operator's distance from drone multiplied by 5.
- ▶ Our jammer can operate in barrage and sweep **modes**. With directive or omnidirectional antennas.
- ▶ Make sure you have **proper permit** to use it.
- ▶ Our anti-drone system is integrated with **hard-kill** systems:
VSHORAD,
Active Protection System (APS),
Vehicle Protection System (VPS)
- ▶ Ultra-precise 3D MIMO **tracking radar** is recommended for fire control.



▶ **PROPRIETARY SOFT KILL – Multi-Band Jammer
HARD KILL INTEGRATION**



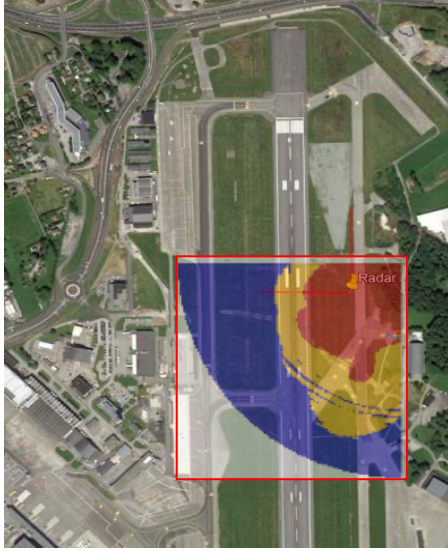

▶ Civil airports, Prisons, Critical infrastructure, Server centers

▶ Military bases.

▶ Wind farms.

▶ EXAMPLE APPLICATIONS WITH APS TECH DEPLOYMENT



THE PORT OF GDYNIA CASE



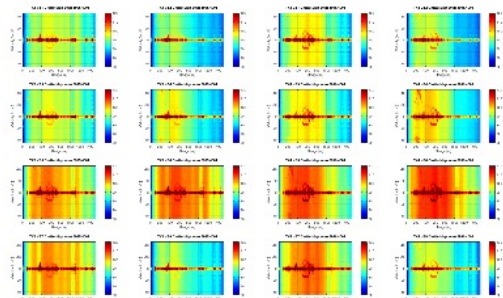
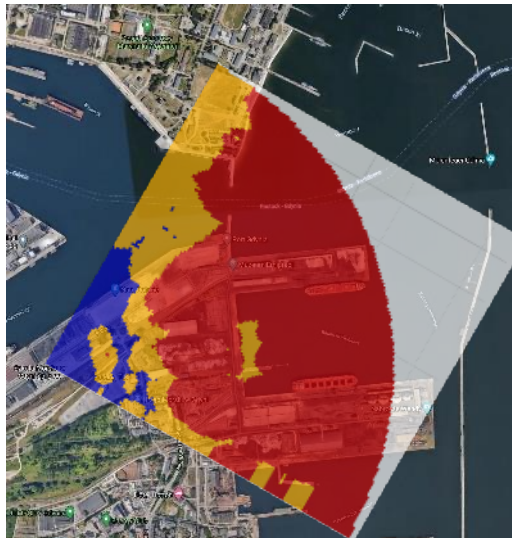

A universal **modern port** specializing in handling general cargo, linked to the Corridor VI of the Trans-European Transport Network.



We have been chosen as a **trusted project partner** for an anti-drone solution deployment scheduled for 2020.



Port area is placed in a **challenging industrial** environment filled with various buildings, moving machines, electric installations.



Our proprietary **prediction software tool** was used to estimate detection range, determine key components of configuration and milestones of the deployment.



Several site surveys had to be performed **to establish** optimal placement of the system, its configuration, electrical and ethernet connectivity, stable mounting with regards to weight of the system and wind conditions.



**WE SUCCESSFULLY DEPLOY OUR CUAS SYSTEM
IN CHALLENGING ENVIRONMENT**



AVINOR STAVANGER AIRPORT



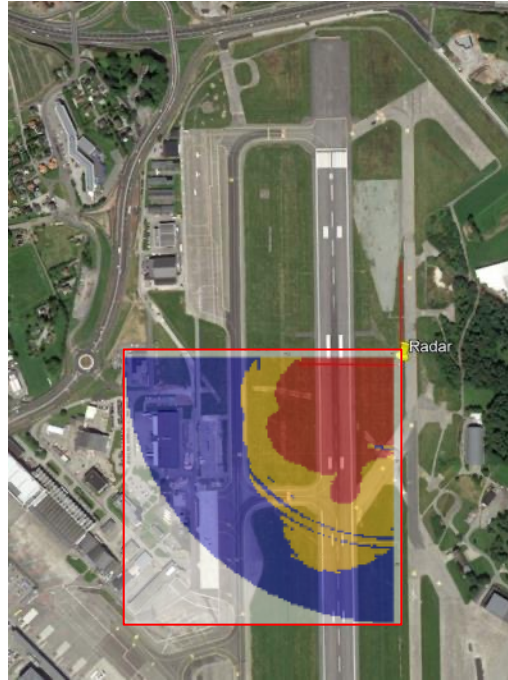

▶ Our multi sensor system has been selected by AVINOR, Norway's civil airport management company, as their preferred counter drone and bird detection system.

▶ We won an 8 year contract and have already successfully deployed the system at Stavanger Airport.

▶ Even though airfield is quite open area without many obstructive infrastructure, **detection predictions** were performed thoroughly.

▶ Quality of predictions was later confirmed with real-life detection of nano-drones during test flights.

▶ Few dozens of drone flights in a windy airfield area were performed to **fine-tune tracker and classifier** in order to minimise false detection.

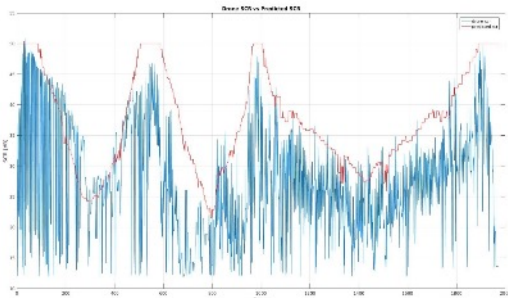

▶ WE SUCCESSFULLY DEPLOY OUR CUAS SYSTEM IN CHALLENGING ENVIRONMENT



WHO WE ARE AND WHAT WE STAND FOR



Maciej Klemm, PhD
Cofounder, CEO



Radosław Piesiewicz, PhD
Cofounder, COO

MSc degree in Microwave Engineering and Optical Communications from the Technical University of Gdańsk, Poland and **PhD degree** in electromagnetics and microwave engineering with summa cum laude from **ETH (Swiss Federal Institute of Technology), Zurich, Switzerland.**

Author of over 50 scientific publications on ICT, including several breaking through papers on **electromagnetics and nano antennas**. H-index = 24.

Associate Professor at Department of Electrical and Electronics at the **University of Bristol, UK.**

Winner of the **Best Young British Research Engineer** competition, awarded by Tony Blair, Prime Minister of the United Kingdom.

Awarded with Engineering and Physical Sciences Research Council (EPSRC) Research Fellow in Dynamic Microwave Imaging.



MSc degree in Microwave Engineering and Optical Communications from the Technical University of Gdańsk, Poland and **PhD degree** in THz communications technology with summa cum laude from **Braunschweig University of Technology, Germany.**

Author of over 105 scientific publications on ICT including several breaking through papers on **THz communication**. H-index = 24.

Distinguished or invited speaker and panelist at several conferences incl.

- C-UAS workshop by **European Defence Agency**, Belgium, 2020,
- 4th EU Summit on the Future Internet, Portugal, 2013,
- European Wireless, UK, 2013,
- **IEEE CrownCom**, Germany, 2009,
- FP7 ICT Event, France, 2008.

Leader and researcher in a number of international research projects incl. MEDEA+ MESDIE, MEDEA+ QStream, FP6 Strep Ming-T, FP7 Strep Diconet, C2Power, Fiver, Saphyre, OneFit, Acropolis, FP7 IP EUWB, MAE I-Chip, EUWB – Enlarged Europe.

Manager of various industrial research projects with **CISCO and Airbus GmbH.**

Top manager and head of R&D in several high-tech startups.



INTELLIGENT KNOW-HOW OF THE FOUNDERS



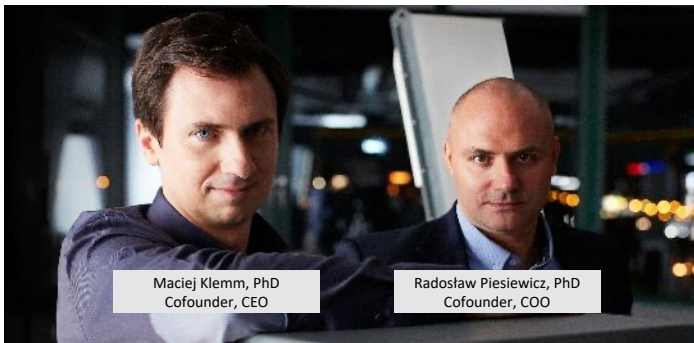

Maciej Klemm, PhD
Cofounder, CEO

Radosław Piesiewicz, PhD
Cofounder, COO



ADVANCED PROTECTION SYSTEMS

We are innovators and engineers who live and breathe tech.
We design and manufacture every crucial component of our products and systems.
From silicon chips through electronics, algorithms, software, to final integration.
And we've been using our unique know-how since 2012. We currently employ 50 engineers.



SKYctrl anti-drone system & FIELDctrl 3D MIMO radars

SKYctrl is based entirely on proprietary in-house solutions and includes four types of sensors: ultra-precise FIELDctrl 3D MIMO radar, PTZ day/night camera, WiFi sensor and acoustic array. MHT and machine learning algorithms, multi-band jammer and secure CyView C2 software ensure manual or automated multi-layer detection and neutralization of each type of drone.

We have already successfully delivered SKYctrl system to many customers representing military and defence industry, uniformed services, critical infrastructure, prisons, ports and airports in countries across Europe, Asia and the Middle East.



AWARDS AND PRIZES

We have been granted not only by the trust of our clients but with prestigious awards and prizes too.



"Defender" award,
for outstanding and innovative
defence solution.
Granted by the Secretary of State
in Ministry of National Defence



President of the Board Award
at the XXV International
Defence Industry Exhibition
(MSPO) in Kielce, Poland



First place in "Innovations
for Security and Defence"
competition.
Organized under the auspices
of the Polish National Security Bureau



Medal
from The Armed Forces
Operational
Command of Poland

 TERRA HEXEN is the official sales representative of APS

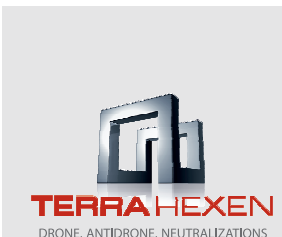

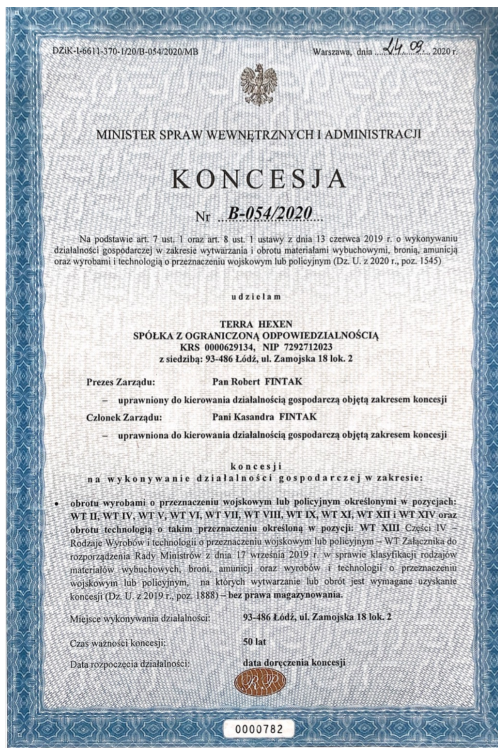

MILITARY CONCESSION

Military Concession
for Manufacturing Military Items
issued by the Polish Ministry
of Interior and Administration



ISO 9001:2015

ISO 9001:2015 Certificate proving Top
Quality of Manufacturing and
Processes



Turnover of Strategic Goods

EU Certificate for Turnover of Strategic
Goods

SECURITY CLEARANCES AND MILITARY CONCESSION ISO 9001:2015 Certified





- ▶ Our modular anti-drone system, SKYctrl was approved by the British government organization CPNI (Centre for the Protection of National Infrastructure).
- ▶ CPNI provides security consultancy to businesses and organizations in the critical national infrastructure sector.
- ▶ As a part of MI5, it is exempt from the Freedom of Information Act.
- ▶ Our technology has passed the strictest tests to verify the reliability of the system we have developed.
- ▶ This approval proves that our counter-drone technology is of the highest quality and effectiveness.

▶ CENTRE FOR THE PROTECTION
OF NATIONAL INFRASTRUCTURE



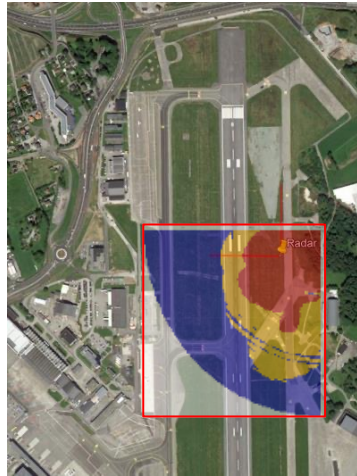

- ▶ Most advanced, proprietary 3D radar technology on the market.
- ▶ Minimal installation costs.
- ▶ Dual detection: drones incl. nano., vehicles/persons.
- ▶ Proprietary prediction software tool to define the optimal configuration and facilitate deployment.
- ▶ API delivered for easy radar integration
- ▶ Approved by CPNI, British government organisation.
- ▶ ISO 9001:2015 certified, Military Export License, NATO Secret Level Clearance.

▶ COMPETITIVE ADVANTAGES





Let's talk and find out what we can do for you..

E-mail us at Robert.Fintak@terrahexen.com
or call at **+48 505 17 60 31** (European Union, CET).



LET'S WIN THIS THING TOGETHER

